

If you no longer want to receive marketing emails from Twin Commander, please unsubscribe using the link at the bottom of this email.



Introducing the new Twin Commander Newsletter!

After taking a few months away to think about how we can improve the way we communicate with you, we're pleased to introduce this new exclusive newsletter.

The Twin Commander Newsletter is home to the latest Twin updates, exclusive behind-the-scenes content from the factory, and the scoop on promotions from our distribution partners.

Look out for the next issue, featuring a spotlight on our Twin Commander Factory Authorized Service Centers, your exclusive source for Twin Commander parts and service.

Meet Ali Fallon, our new Head of Twin Commander

Long-time Ontic engineer, Alistair Fallon, was named Value Stream Director for the company's Type Certificate group, earlier this year. This includes responsibility for the full line of Twin Commander models. Fallon previously served as Engineering Manager for Ontic's Creedmoor facility, primarily focused on products installed on Boeing aircraft.

"I love the heritage of the Twin Commander line of aircraft," he said. "And I'm excited to serve this passionate group of owners and the vibrant community that supports them."

[Read the full announcement here](#)



Shoulder Harnesses Required for Firefighting Aircraft

Under new rules announced by the U.S. Forestry Service, all aircraft engaged in firefighting operations must be equipped with suitable shoulder harnesses by the start of the 2025 fire season.

In order to help operators prepare, Twin Commander has developed **Custom Kit 208**. The kit includes all the hardware necessary and belts to add shoulder harnesses to the two middle passenger seats in the forward and rear-facing configuration, and the two outer seats on the rear bench.

Passenger Shoulder Harness

Initially effective for these Models:
690/A/B/C and 695
Additional models to follow

Provides additional adjustable fixed Shoulder Harness for passenger seating. Increases levels of safety during turbulence, take off, taxi, and landing. Shoulder Harness installations can accommodate a range of seating floor plans for aft and forward-facing seats.

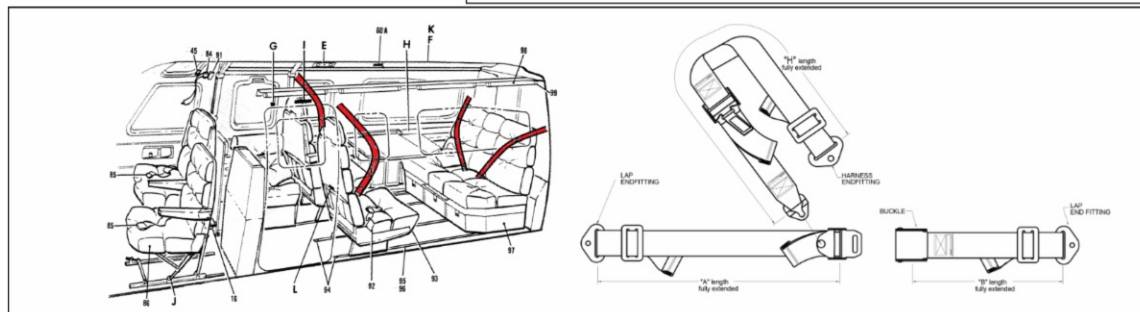

CK208-1 covers the 690 platform, while CK208-2 covers the 690A/B/C and 695 platforms. Installation time is estimated at 40 hours. Adding the kit will fully comply with the Forestry Service requirements and prepare operators for the 2025 season. The belts are manufactured by Twin Commander sister company ABI, and personalization options are coming soon. You don't have to engage in firefighting operations to add the kit. The FAA estimates that shoulder harnesses reduce serious injury by 50 percent, making them a great safety investment for any owner or operator.

Contact your preferred [Twin Commander Factory Authorized Service Center](#) for pricing, or to request additional model support.

A Brand New Look

The Twin Commander website has a new look. In an effort to better serve owners and Twin Commander Factory Authorized Service Centers, Ontic has completely redesigned the Twin Commander site.

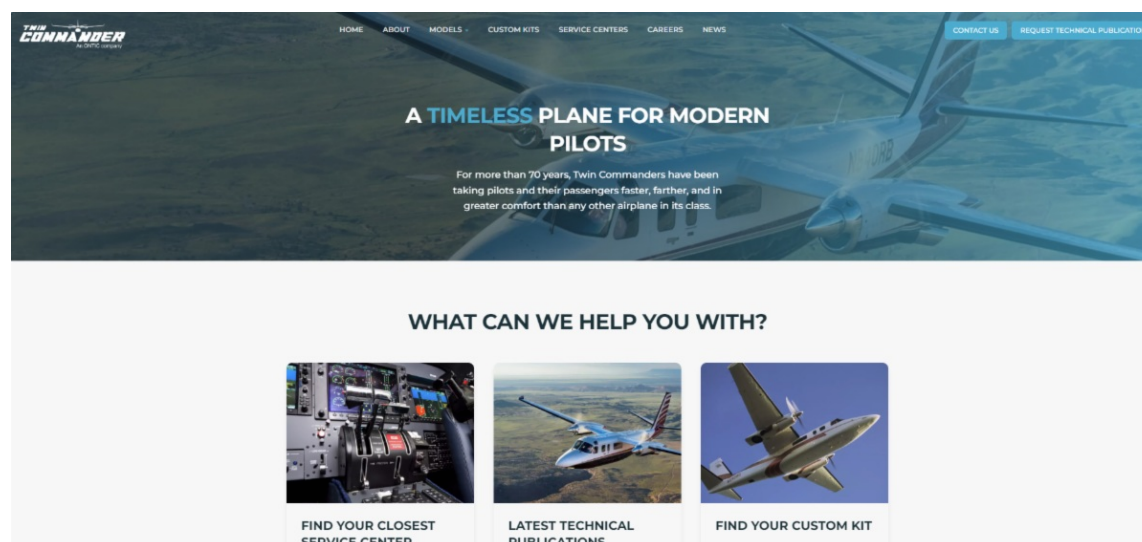

The new site makes it easy to learn more about each model, discover the range of Custom Kits, locate a Factory Authorized Service Center, connect with technical publications, and contact the factory.

“Ontic is a large, multinational corporation that has the resources to push Twin Commander forward,” says Ali Fallon. “By bringing together the heritage of the Twin Commander line of aircraft with the reach of Ontic, we think owners will benefit with an enhanced experience.”

The new site demonstrates that commitment with contact information that’s easy to find, a direct line to Factory Authorized Service Centers, and ready access to technical publications. Plus, in an effort to further demonstrate the company’s commitment to service, there’s a dedicated AOG support page with resources to get owners back in the air faster than ever. Ali continues, “I’m excited to show the Twin Commander world the benefits Ontic can bring to owners and Factory Authorized Service Centers, and I think our new website is a tangible benefit of that commitment and investment.”

[Visit the new site](#)

Flight Levels Online Archive

You might notice that the previous Flight Levels Online (FLO) website is now also offline. If you still like revisiting articles from the past few years, don't fret; we have an archive of FLO on the new Twin Commander website.

Although not every issue is currently available, we're working to get the full FLO archive online by Christmas.

[Take me to the FLO archive](#)

Get in touch

If you need to speak to one of our team members, please get in touch below. If you need to order a new part, please contact one of our [service centers](#).

[Contact us](#)



If you no longer want to receive marketing emails from Twin Commander, please unsubscribe using the link at the bottom of this email.

The **ONTIC** Group
More than the sum of our parts

TWIN COMMANDER
An ONTIC company

ap filtration
an ONTIC Company

CENTROID INC.
An ONTIC company

Metro Merlin Aircraft
an ONTIC Company

AIRCRAFT BELTS, INC.
an ONTIC Company

Twin Commander | 1176 Telecom Dr | Creedmoor, NC 27522 US

[Unsubscribe](#) | [Update Profile](#) | [Constant Contact Data Notice](#)



Try email marketing for free today!